

NUMBER: SB 550-32-003, Rev E
MODEL: ECLIPSE 550®
SUBJECT: Left Hand MLG Trunnion Repair/Replacement

Mandatory

www.ECLIPSE.aero

1. PLANNING INFORMATION

A. Effectivity

Aircraft Serial Numbers: 550-0263 to 550-0265, 550-0268 to 550-0280, 550-0282 to 550-0284, and 550-1001, Post SB 550-32-002.

B. Reason

This bulletin repairs or replaces the main landing gear trunnion.

Revision E of this Service Bulletin limits the effectivity and updates the compliance section.

Revision D of this Service Bulletin includes the following changes:

- SB type updated from Recommended to Mandatory.
- Updated the compliance statement.
- Updated to include Authorized Facilities list with facilities authorized to replace or repair.
- Updated accomplishment instructions to include repair or replace based upon authorized facility.

Revision C changes: Updated Authorized Facilities list to reference SB 550-32-002.

Revision B changes: Updated to include Mecaer CMM 32-11-41 — Main Landing Gear and Epoxy Paste Adhesive — HYSOL EA934NA.

C. Description

This Service Bulletin provides procedures to repair or replace the Main Landing Gear Trunnion on an Eclipse aircraft.

D. Relevant Publications

06-123838, Eclipse 550 AMM, current revision

E. Compliance

Eclipse Aerospace Incorporated considers this to be a mandatory procedure that must be accomplished by the next 300 hour / 24 month inspection or no later than 31 December, 2016.

Compliance with revisions A, B, C or D does constitute compliance with Rev E.

This Service Bulletin must be accomplished at an Eclipse Aerospace Authorized facility.

NOTES:

1. If repairing the trunnion, SB 550-32-002 must be completed prior to, or in conjunction with, this Service Bulletin.
2. Replacing BOTH the LH trunnion per this service bulletin & the RH trunnion per SB 550-32-004 does constitute compliance with SB 550-32-002.

F. Approval

This Modification Bulletin is based on engineering data that is FAA-approved, and the modification herein complies with the applicable regulations.

G. Labor Requirements

The following information is for planning purposes only.

(1) Estimated labor hours to perform **REPLACEMENT**:

Suggested number of personnel: 1

Log book review: 0.5 Hrs

Removal / Installation of Trunnion: 20 Hrs

Total labor hours: 20.5 HOURS

(2) Estimated labor hours to perform **REPAIR**:

Suggested number of personnel: 1

Log book review: 0.5 Hrs

Removal / Installation of Trunnion: 20 Hrs

Repair of Trunnion: 5 Hrs

Total labor hours: 25.5 HOURS

The above is an estimate based on properly equipped and experienced personnel complying with this Service Bulletin. Actual labor hours may vary depending on workforce experience, concurrent maintenance, discovery of other discrepancies, etc.

(3) Qualification of personnel:

- A person properly authorized under 14 CFR 43 to perform aircraft maintenance.
- Personnel performing or inspecting the LG trunnion repair shall have received training by a Mecaer America Inc employee.

(4) Facilities Authorized to perform Service Bulletin:

REPLACEMENT Authorized Facilities	REPAIR Authorized Facilities
Eclipse Aerospace, Inc. (ABQ, PWK)	Eclipse Aerospace, Inc. (ABQ, PWK)
AIRplus Maintenance GMBH, Friedrichshafen, Germany	Boca Aircraft Maintenance, Boca Raton, FL USA
Boca Aircraft Maintenance, Boca Raton, FL USA	
C2 Aviation Ltd, Kemble, Cotswold Airport, Cirencester, Gloucestershire, UK	
Crownair Aviation, San Diego, CA USA	
General Enterprises B.V., Machlaan 8a, 9761 TK Eelde, The Netherlands	
Genel Havacilik A.S., Atatürk International Airport (IST), Istanbul Turkey	

H. Weight and Balance Change

N/A

I. Electrical Load Data Change

N/A

J. Software Accomplishment Summary

N/A

K. References

06-123838, Eclipse 550 AMM, current revision

SB 550-32-002, current revision

Eclipse Work Instruction 32-124848-1001 — Main Landing Gear Trunnion Repair

L. Publications Affected

N/A

M. Export Control

These commodities, technology or software were exported from the United States in accordance with the Export Administration Regulations. These commodities, technology or software are intended for use only in the End User’s country. An export license from the U.S. Department of Commerce may be required before these products can be re-exported, transferred, transshipped on a non-continuous voyage, or otherwise disposed of in any other country, either in their original form or after being incorporated into an end item. Diversion of this end-item or its use contrary to any applicable U.S. government license or to U.S. law is prohibited.

2. MATERIAL INFORMATION

A. Materials

M041-07H129-045 — Main Fitting Assembly (LH)
MSC0027-125 — (LH) MLG Main Fitting nameplate

B. Consumables

Aliphatic Naptha TT-N-95B Type II (or equivalent)
Epoxy Adhesive MMM-A-132, Type 1, Class 3 (Metalset A4 or equivalent)
Epoxy Paste Adhesive — HYSOL EA934NA

C. Consumables

N/A

D. Tooling

N/A

E. Cost

Contact Eclipse Aerospace Customer Care for cost information and availability.

3. ACCOMPLISHMENT INSTRUCTIONS

A. Review Log Book

- (1) Review log book entries, proceed based upon the following:
 - (a) If trunnion was replaced per TSR from EAI, POST SB 550-32-012, and contains a Service Bulletin (SB) number and/or a DDR# as shown in [Figure 2](#), complete compliance record and return to EAI. No further work under this SB is required.
 - (b) If trunnion was not replaced, based on facility authorization, repair or replace trunnion per step 3.B. or 3.C. of this bulletin, as applicable. See “Facilities Authorized to perform Service Bulletin:” on [page 3](#).

B. Repair MLG Trunnion

- (1) Perform the following to repair the trunnion:
 - [Section D. — Job Set-Up](#)
 - [Eclipse Work Instruction 32-124848-1001 — Main Landing Gear Trunnion Repair.](#)
 - [Section F. — MLG Main Fitting Installation](#)
 - [Section G. — Job Close-Up](#)

C. Replace MLG Trunnion

- (1) Perform the following to replace the trunnion:
 - [Section D. — Job Set-Up](#)
 - [Section E. — MLG Nameplate Installation](#)
 - [Section F. — MLG Main Fitting Installation](#)
 - [Section G. — Job Close-Up](#)

D. Job Set-Up

- (1) Make aircraft safe for maintenance. Refer to AMM 20-00-01 – MAKE SAFE FOR MAINTENANCE.
- (2) Remove the MLG Trunnion. Refer to AMM-32-10-17-001 — MAIN LANDING GEAR TRUNNION ASSEMBLY - REMOVAL, or Mecaer CMM 32-11-41 — Main Landing Gear.

E. MLG Nameplate Installation

CAUTION: DO NOT mark the nameplate while it is installed on the trunnion.

- (1) Transfer information from original nameplate to new nameplate prior to installation of the new nameplate. Information can be marked on new nameplate through any permanent marking method (e.g. stamping, laser engrave, vibro-etch). Non-physical marking (e.g. permanent marker, ink stamp, etc.) is not acceptable.
- (2) The format and information contained on most original nameplates is not the same as the new nameplates. If the original nameplate is identical in format to the new nameplate, transfer the information directly. If the original nameplate is a different format, transfer the information to its equivalent listed in the table below:

Original Nameplate Equivalent	New Nameplate Equivalent
MFR P/N	P/N
MOD STD	DDS REV
ECLIPSE AVIATION SPEC No. and Rev	No equivalent (no data required)
SERIAL No	S/N
MFG DATE	ASSY DATE
No equivalent	DDS M041-
No equivalent	INSPECTION

- (3) MFG DATE/ASSY DATE to remain as on the original nameplate (do not change the date to the current date).
- (4) Original nameplate shall have a large black “X” marked across the nameplate from corner to corner with permanent marker to void the nameplate. Original nameplate to remain attached to the old Main Fitting.
- (5) Locate position for new nameplate installation on the new MLG Main Fitting 44-46 mm (1.73-1.81 inch) up from the lower strengthening band in accordance with [Figure 1](#).
- (6) Pre-bend new Nameplate to conform to the contour of Main Fitting.

CAUTION: ONLY USE THE CLEANING SOLUTION IN A WELL VENTILATED AREA. AVOID SPARK OR FLAME.

CAUTION: ONLY USE CLEAN PAPER OR COTTON CLOTHS FOR CLEANING (DO NOT USE SYNTHETIC FIBRE CLOTHS).

- (7) Prepare the Main Fitting surface in the location of the nameplate by thoroughly cleaning the surface with Aliphatic Naptha TT-N-95B Type II (or equivalent).
- (8) Ensure the Main Fitting surface is completely dry after cleaning by using a clean dry cloth.
- (9) Remove adhesive backing from the nameplate.
- (10) Apply Epoxy Adhesive MMM-A-132, Type 1, Class 3 (Metalset A4 or equivalent) under the entire surface of the nameplate.
- (11) Attach the nameplate to the MLG Main Fitting in the correct location.

- (12) Apply liberal bead of adhesive around all edges of nameplate.
- (13) Temporarily secure nameplate to Main Fitting using non-marking tape (Masking Tape or equivalent).
- (14) Allow adhesive to dry.
- (15) Remove temporary tape.
- (16) Install Trunnion per Section F. — MLG Main Fitting Installation.

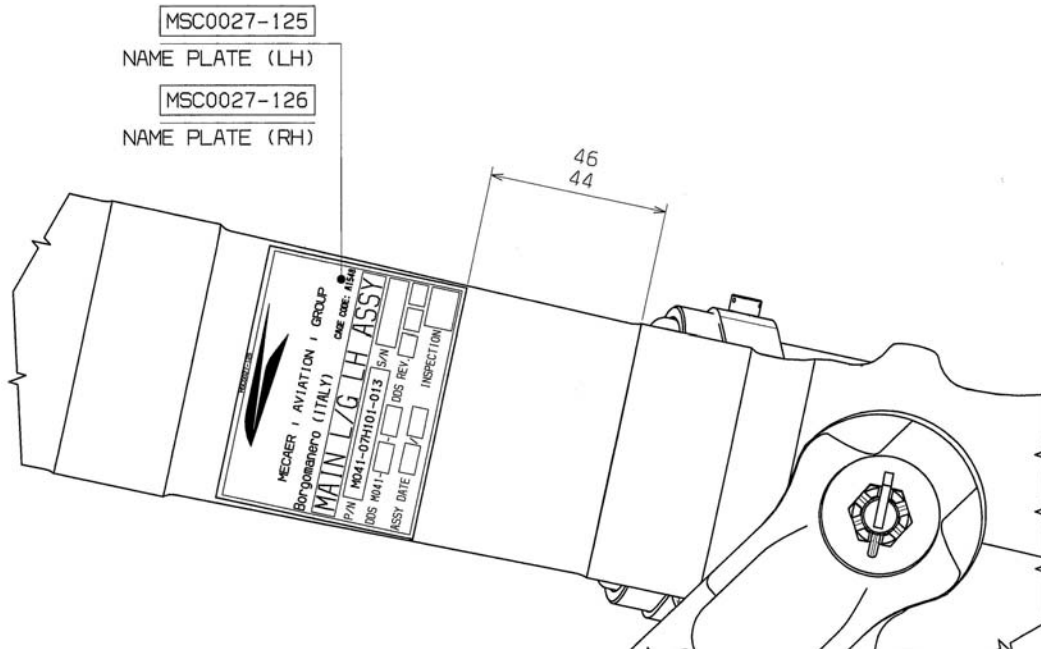

Figure 1. MLG Main Fitting Nameplate Location

F. MLG Main Fitting Installation

- (1) Ensure the replacement trunnion contains at least one of the following (Refer to Figure 2):
 - Marked indication of SB completion on or near the identification pad area.
(Accomplished after repair procedure.)
 - Engraved DDR# from Mecaer on the identification pad.

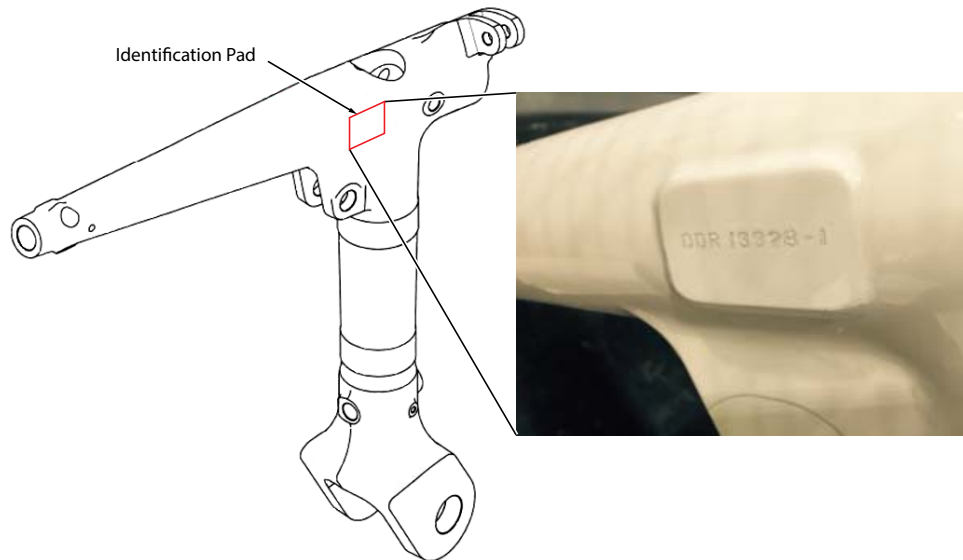

Figure 2. Trunnion Identification Pad Area

CAUTION: WHEN PERFORMING INITIAL GEAR SWINGS AFTER REPLACING A TRUNNION, CAUTION SHOULD BE EXERCISED TO MINIMIZE THE POSSIBILITY OF DAMAGING A GEAR DOOR. ADJUSTMENT OF THE MAIN GEAR DOOR PER AMM-52-82-00-071-801 MAY BE REQUIRED AFTER REPLACEMENT OF A MAIN GEAR TRUNNION.

- (2) Install the MLG Trunnion. Refer to AMM-32-10-17-001 — MAIN LANDING GEAR TRUNNION ASSEMBLY - INSTALLATION, or Mecaer CMM 32-11-41 — Main Landing Gear.

G. Job Close-Up

- (3) If all other maintenance is complete, return aircraft to service. Refer to AMM 20-00-02-051-801 RETURN TO SERVICE (AFTER MAINTENANCE).

H. Limitations and Procedures

N/A

I. Parts Disposition

Return the removed parts to supplier for evaluation and possible repair. Parts to be packaged carefully to prevent damage during shipping.

4. RECORD OF COMPLIANCE

Upon completion of this Service Bulletin, make an appropriate maintenance-record entry specifying the Service Bulletin number.

5. NOTIFYING ECLIPSE AEROSPACE

On completing this Service Bulletin, the operator/maintainer shall complete the attached Compliance Record and any completed forms from the repair work instruction if applicable, and send to Eclipse Aerospace via regular mail, fax, or e-mail.

Mailing Address	Eclipse Aerospace Incorporated ATTN: Service Engineering 2503 Clark Carr Loop SE Albuquerque, NM 87106
Fax	1-505-241-8802
E-mail	sbcompliance@eclipse.aero

[Intentionally Blank Page]

